

[DUAL FUEL RANGE – 3009GNM-M / SIG-90]

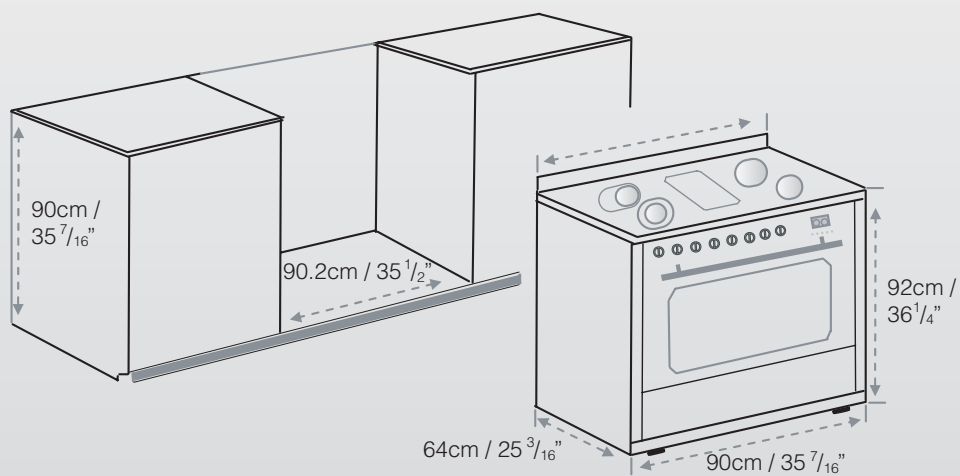

SIG 90 - ELECTRICAL REQUIREMENT:

208/230 Volt/60Hz 30 AMP

Dims:

92cm H x 90cm W x 60/64cm D

36¹/₄" H x 35⁷/₁₆" W x 23⁵/₈/25³/₁₆" D