

[ ELECTRIC RANGE - 3009VNM-M / SIC-90 ]

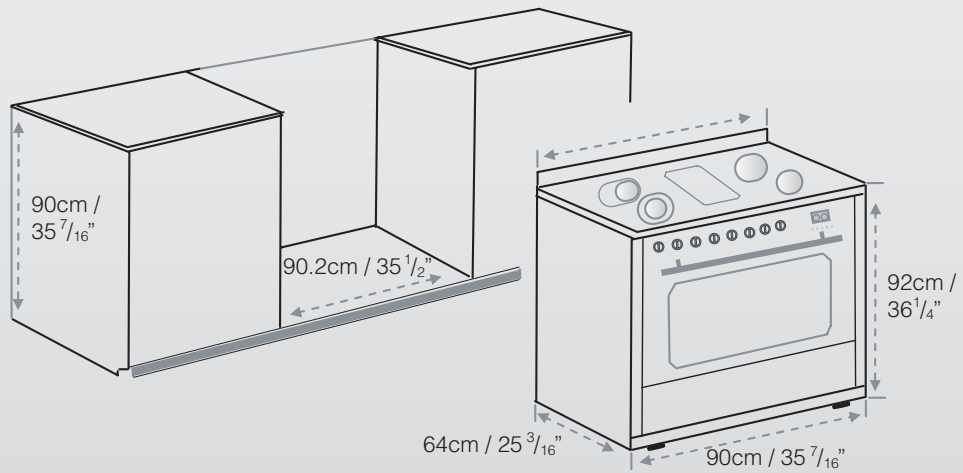

SIC 90 - ELECTRICAL REQUIREMENT:

208/230 Volt/60Hz 40 AMP

Dims:

92cm H x 90cm W x 60/64cm D

36<sup>1</sup>/<sub>4</sub>" H x 35<sup>7</sup>/<sub>16</sub>" W x 23<sup>5</sup>/<sub>8</sub>/25<sup>3</sup>/<sub>16</sub>" D